

Egg-Shelves, Assembly Manual



PARTS LIST

2 = Shelves, 2 = Left Shelf Brackets, 2 = Right Shelf Brackets

2 = Interface brackets

1 = Hardware bag

(8) = 1/4" x 3/16" Shoulder screws (8) = 8-32 Nylock nuts (4) = 1/4"-20 Keps nuts

(4) = 1/4"-20 x 5/8" Clinch studs (4) = Utensil S-hooks (8) = 8-32 SEMS screws

Step 1. **Attaching the Shelf Brackets to the Shelves:** Position one of the shelves face down on a working surface that won't scratch the face of the shelf. Locate and position (1) left and (1) right shelf bracket onto the shelf as in Illustration A. *It is possible to attach the table brackets incorrectly, so please make sure your shelf assembly looks exactly like Illustration A.* Insert (1) 8-32 SEMS screw through the hole in the shelf bracket then into the corresponding threaded brass insert that is molded into the shelf. (Note: *If you are at all like me, you can't resist using your new cordless driver / drill for all your fastener installation needs. I strongly urge you to resist temptation and leave the power tool on the workbench. The plastic material the shelves are made of is some of the best available, but even it has it's limitations and if you use a power tool to tighten the fasteners you may prove my point*) Use a #2 Phillips hand held screw driver to start the screw into the insert, repeat this at the remaining (3) locations then gently tighten all (4) screws. Repeat this procedure for the remaining shelf.

Illustration A

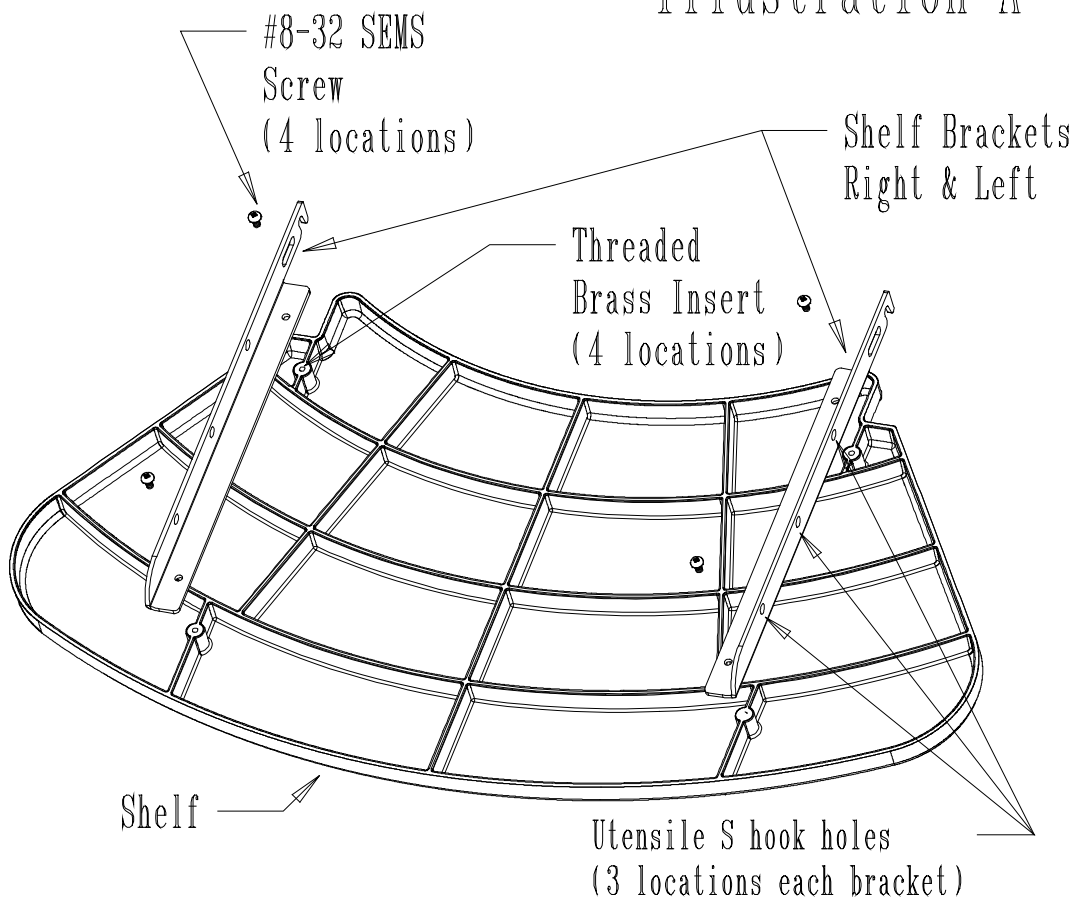

STEP 2. **Attaching the interface brackets:** **(WARNING)** *If you are working with a Spring Assisted Band, be certain that you reinstall the shipping retainer bar/s, or prevent the hinge from opening by some other method before proceeding or the spring tension could cause the hinge to snap open or closed possibly causing personal injury or damage to the grill unit.* If you are adding Egg-Shelves to an existing Egg, you will need to remove the lower band-tensioning bolt in order to insert the (4) 1/4"-20 x 5/8" clinch studs. Insert the clinch studs from the inside of the lower band outward then install and hand tighten a 1/4"-20 Keps nut onto each stud to hold them in place while reinstalling the band onto the Egg. Install the band onto the Egg and securely tighten the band-tensioning bolt. Remove the Keps nuts you hand tightened onto the clinch studs. Position one of the slots in the interface brackets onto one of the clinch studs then install and hand tighten a Keps nut. (Note: *the interface brackets have holes and slots closer to one edge than the other, the closer edge is the top*) Position the slot in the opposite end of the interface bracket onto the other stud and install a Keps nut (Illustration B). Repeat this procedure for the remaining interface bracket and tighten all the fasteners.

STEP 3. **Attaching the Shelf Assemblies:** Position one of the shelf assemblies over the ends of one of the interface brackets you installed in step 2. The shelf brackets should fit over the outside of the interface bracket ends. Check the gap between the interface bracket and the shelf brackets. You may need to slightly bend the interface bracket ends from side to side in order to achieve a small and parallel / even gap between them, *(the gap only needs to be wide enough to allow the shelf assembly to slide in and out freely to engage and disengage the latching mechanism)*. When the gap is even, set the shelf assembly aside and insert a 1/4" x 3/16" shoulder screw from the outside inward through the inner hole *(hole closest to the egg)* at either end of the interface bracket, install an 8-32 nylock nut and tighten. Repeat this at the inner hole in the opposite end of the interface bracket also. Position the shelf assembly over the interface bracket and insert a 1/4" x 3/16" shoulder screw through the slotted hole in the table bracket then through the outer hole in the interface bracket and install an 8-32 nylock nut. Repeat this at the slotted hole in the opposite side of the shelf assembly and tighten the nuts at both locations. Repeat this procedure for the remaining shelf assembly.

Illustration B

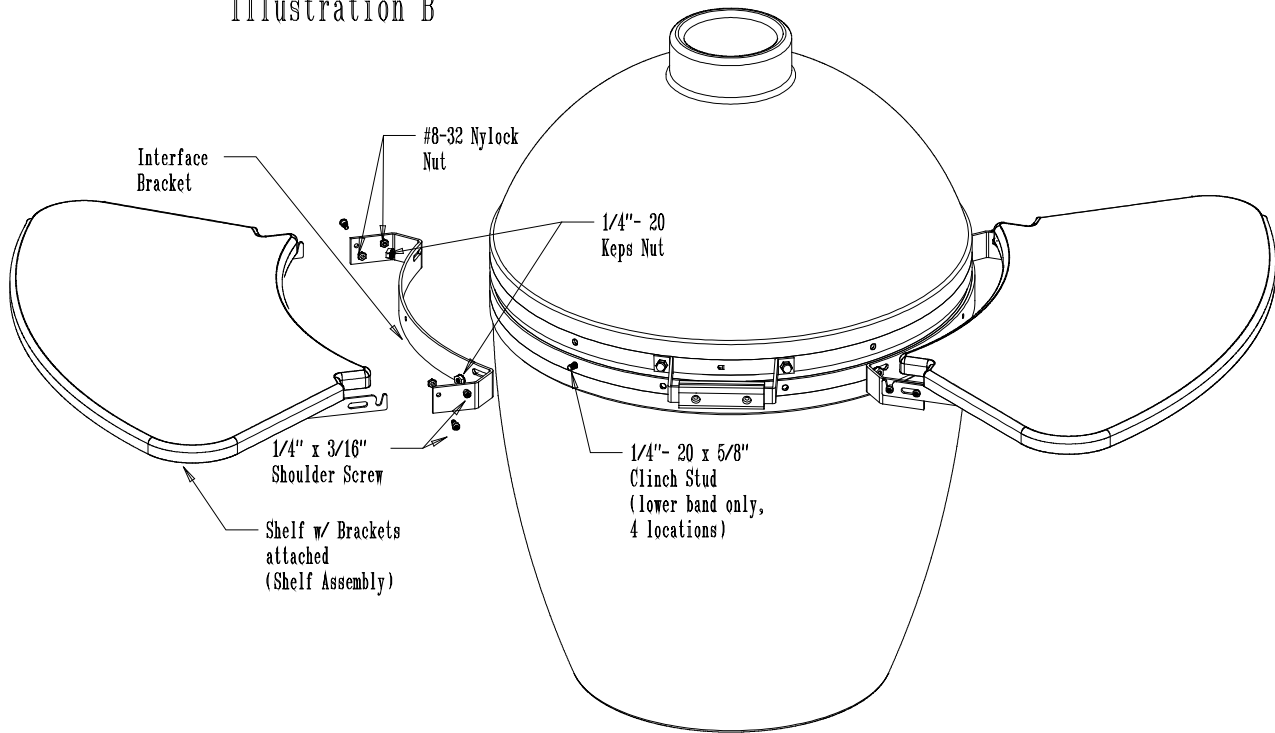

Congratulations, you have completed the installation of your Egg-Shelves. Simply lift up the Shelf and slide it in or out to engage or disengage the latch mechanism. This product was designed and manufactured in the U.S.A. exclusively for Big Green Egg. Thank you for your purchase.

Note: The shelves are molded from the highest quality plastic materials available, engineered specifically to be durable and exceptionally heat resistant. Please keep in mind, even the best materials are not indestructible and very hot items placed on the shelf surfaces may permanently discolor or char the surface.

Safety

- ▲ Always be certain both latches are engaged before use.
- ▲ Do not place heavy objects on the shelves.
- ▲ Do not sit or lean on shelves.
- ▲ Do not place combustible materials on shelves while charcoal is ignited.
- ▲ Do not let children sit, hang, swing, or pull them up on the shelves.
- ▲ Do not lift cooker by the shelves or brackets.
- ▲ Use only on a stable & level surface.